

Z329 FUNNEL CONVERTING ASSEMBLY



ENGINEERING SPECIFICATION

Zurn Z329 7" or 9" (specify) oval funnel converting assembly features Dura-Coated cast iron (or finish to suit drain top), along with necessary fasteners to secure funnel to strainer. (Available on 7" diameter or larger size drain tops only.)

Product Designation	Dimensions in inches [mm]			Approximate Weight lb [kg]
	L	L'	U	
-7	6-3/4 [171]	3 [76]	1 [25]	2 [1]
-9	8-7/8 [225]	3-5/8 [92]	3-3/4 [95]	4 [2]

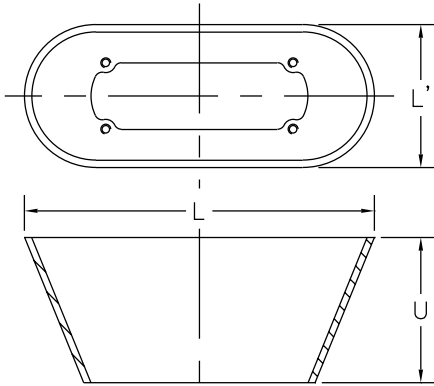

PREFIXES	DESCRIPTION	PRODUCT DESIGNATION	LIST PRICE
Z329*	D.C.C.I. Funnel	-7	178.00
		-9	421.00
ZN329	Polished Nickel Bronze Funnel	-7	421.00
		-9	874.00
SUFFIXES			ADD
-AR	Acid Resisting Epoxy Coated Cast Iron		206.00
BEST SELLERS			LIST PRICE
ZN329-7			421.00
ZN329-9			874.00

Supplied By:



877-903-7246

www.commercialplumbingsupply.com

*Regularly furnished unless otherwise specified.

Items designated as Best Sellers are most specified and are generally in stock for shipment.

⌚ This symbol denotes a product that is engineered to reduce installation and rework time.

For additional product information, please visit www.zurn.com